

SKID STEER LOADERS

**SR130 | SR150 | SR175 | SV185 | SR200
SR220 | SV250 | SR250 | SV300**

CASE

CONSTRUCTION



**POWER OUTSIDE,
COMFORT INSIDE**

www.casece.com

**EXPERTS FOR THE REAL WORLD
SINCE 1842**

POWER OUTSIDE, COMFORT INSIDE



PACKAGED POWER SINCE 1969

Since the first model 1530 Uni-Loader, Case has built its reputation around power, productivity and reliability. This has been achieved through the introduction of innovative features such as the exclusive Ride Control and side lighting.



BIG ON POWER, BIG ON COMFORT

Whatever your job, Case has a skid steer loader that can handle it. Our new extended line-up of skid steer loaders delivers:

- More power
- Increased stability
- Greater operator comfort and visibility
- Best-in-class serviceability
- Wide range of attachments

EXTENDED LINE-UP

To deliver Case performance and productivity to an ever wider range of customers, Case Construction Equipment has expanded its skid steer loader line-up. The revised range includes six radial lift SR boom skid steers and three vertical lift SV models.

SKID STEER LOADERS



CASE POWER STANCE DELIVERS MAXIMUM STABILITY

Our Power Stance chassis rides on a 21 percent longer wheelbase, delivering greater stability and comfort and allowing increased lifting capabilities, regardless of jobsite conditions.

BEST-IN-CLASS BREAKOUT FORCES

The cylinder geometry optimises the skid steer loader's push and pull power, while the bucket support baring directly on the chassis of the machine further adds to its pushing power.

With these features, Case skid steer loaders deliver best-in-class bucket and lift breakout forces.



Chassis supports pushing power!



25% WIDER CAB

It's not just the range that has expanded: all models benefit from a cab with up to 25% more internal width, providing greatly improved operator comfort. Our cab - the widest in the industry - provides plenty of room for comfortable operation, with greater headroom and legroom, more space between the control levers and easy access to the seat.



LEADING OPERATOR COMFORT

The wide door, repositioned grab handles and a lower threshold provide easy access to the cab. All models have suspension seats and optional air suspension heated seats for the ultimate in comfort. If specified with full cab glazing and door, the cab is completely sealed to reduce the amount of noise and dust.

SKID STEER **LOADERS**



360-DEGREE VISIBILITY

The 89 cm wide cab together with larger windows and a new ultra-narrow wire side-screen provide outstanding visibility all around the jobsite, allowing safer operation.

INCREASED PRODUCTIVITY AND SAFETY

The larger side windows offer visibility over the tyres and the forward cab design provide a clear line of sight to the cutting edge of the bucket improving both productivity and safety.

CONTROLS AT YOUR FINGERTIPS

All controls are within easy reach and you can choose between standard mechanical (hand- or foot-controlled) drive levers and electro-hydraulic controls.

Electro-hydraulic controls settings can be modified from the instrument cluster increasing or decreasing machine, boom and bucket speed, or simply making the joysticks more or less reactive.

Optional Ride Control provides superior stability and operating speeds, regardless of jobsite conditions.

Optional Self Levelling system keeps the bucket parallel to the ground when the loader arm is raised reducing material spillage and making pallet handling easier.



MECHANICAL HAND CONTROLS



SWITCHABLE CONTROLS

With the electrohydraulic joysticks you can set the control pattern to match your preferences, switching between ISO- and H-patterns just by clicking one button.



UNIQUE SIDE LIGHTS

Working longer days even in winter is easy thanks to the unique Case side lighting system.



SKID STEER LOADERS



BEST-IN-CLASS SERVICEABILITY

Easy access, daily service points grouped together and remote mounted filters mean it's easy to keep Case skid steer loaders working to their maximum efficiency.

SMART BATTERY AND DRAIN HOSES ACCESS

Battery and environmental drain hoses are easily accessible from the side of the machine, by removing a tap located behind the rear wheel, allowing quick service and fast maintenance activities.

CONVENIENT CAB TILTING

With just two retaining bolts, the cab is easy to tilt, providing access to hydraulic and transmission components when necessary. A safety locking system that prevents the cab from dropping is automatically activated.



SKID STEER LOADERS



AN ATTACHMENT FOR EVERY JOB

Case skid steer loaders can handle a broad range of attachments, providing outstanding versatility to serve a broad range of industries.



CONNECT UNDER PRESSURE (CUP)

The CUP standard feature allows you to connect tool hoses without a wrench.



HANDLE ATTACHMENTS EASILY!

Hydraulic Coupler Option: An optional hydraulic attachment coupler increases both operator comfort and uptime on the job site since attachments can be exchanged quickly and safely without leaving the cab.

TYRE OPTIONS

FUNCTIONAL VARIANTE	TYRE DESCRIPTION	SR130	SR150	SR175	SV185	SR200	SR220	SV250	SR250	SV300
8501207	10x16.5 Heavy Duty 590TW	x	x							
8501307	10x16.5 Premium 590TW	x	x							
8501407	10x16.5 Premium Liner 590TW	x	x							
8501507	27x10.5-15 Premium 640TW	x	x							
8502107	10x16.5 Non-Pneumatic 640TW	x	x	x	x	x				
8501707	10x16.5 Heavy Duty 640TW			x	x	x				
8501807	10x16.5 Premium 640TW			x	x	x				
8501907	10x16.5 Premium Liner 640TW			x	x	x				
8502007	10x16.5 Severe Duty 640TW			x	x	x				
8503107	12x16.5 Heavy Duty 700TW			x	x	x	x	x	x	x
8503207	12x16.5 Premium 700TW			x	x	x	x	x	x	x
8503307	12x16.5 Premium Liner 700TW			x	x	x	x	x	x	x
8503407	12x16.5 Severe Duty 700TW					x	x	x	x	x
8503507	12x16.5 Mining 700TW					x	x	x	x	x
8503607	12x16.5 Non-Pneumatic 700TW					x	x	x	x	x
8505007	33x15.5 Flotation 760TW					x	x	x	x	x
8505107	14x17.5 Premium 760TW						x	x	x	x



HEAVY DUTY



PREMIUM & PREMIUM W/LINER



SEVERE DUTY



NON-PNEUMATIC



MINING



FLOTATION

VERSATILITY AND EFFECTIVENESS

EASILY CONNECTED



WHEEL EXCAVATOR



WHEEL COMPACTOR



ASPHALT FLOAT



PLANER



PLANER



BROOM BUCKET



BACKHOE



CEMENT MIXER



COMPACTION ROLLER



PALLET FORK



HAMMER



AUGER



FARM FORK



FORK & GRAPPLE



BALE SPIKE



HIGH TIP BUCKET



4X1 MULTIPURPOSE BUCKET



WIDE RANGE OF BUCKETS

Attachment	Application	Width (mm)	Depth (mm)	Weight (kg)	Flow	Compatible Model
Wheel Excavator	Trenching jobs on hard, compact materials like asphalt and concrete, digging trenches on roads or in areas where movement is restricted.	Wheel width	150 - 450 200 - 600	1.155	High High	SR200 and bigger SR175 / SV185 / SR200
		130 130		1.260		
Wheel Compactor	Compacting the bed of a trench before adding an asphalt surface layer.	Wheel width 200 - 250 - 300 350 - 400	0 - 750	550	Std	SR200 and bigger
Asphalt Float	Backfilling of trenches and widening road surface while maintaining the road's original gradient.	1900	N.A.	620	Std	SR175 and bigger
Planer	Planing on asphalt or concrete. Overlaying road, industrial and courtyard surfaces. Maintenance of stretches of road. Restoration of damaged, bumpy or worn surfaces.	350	0 - 110	590	Std	SR175 and bigger
		450	0 - 150	790	High	SR175 / SV185 / SR200
		600	0 - 170	950	High	SR200 and bigger
		1.000	0 - 130	1.090	High	SR200 and bigger
Broom Bucket	Clearing yards, roads, footpaths, etc. Also efficient for snow clearance.	1.525		225		SR130 / SR150
		1.680		278		SR175 / SV185 / SR200
		1.850		460		SR175 / SV185 / SR200 / SR220 / SV250 / SR250 / SV300
		2.080		522		SR220 and bigger
Backhoe	Creation of trenches, foundations, drain and irrigation channels, etc. in private or public constructions, both for new or maintenance jobs	1.500	2.275	700	Std	SR200 and smaller
		1.500	3.000	790	Std	SR175 and bigger
		1.500	3.500	860	Std	SR220 and bigger
Cement Mixer	Production of cement for civil construction in isolated or difficult-to-access areas, or with limited availability of electric energy	1.250	200	280	Std	SR130; SR150
		1.500	300	300	Std	SR175 and bigger
		1.660	350	380	Std	SR200 and bigger
		1.700	400	450	Std	SR250 and bigger
Compaction Roller	Ground preparation through compaction of earth, gravel, sand, etc.	1100	N.A.	787	Std	All
Pallet Fork	Handling of palletized loads.	Forks length		160		SR200 and smaller
		1.000		164		SR200 and smaller
		1.100		168		All
		1.200				
Hammer	Concrete demolition jobs, trenching and general excavation work			160	Std	SR130 / SR150
				210	Std	SR130 / SR150
				275	Std	SR175 and bigger
				370	High	SR220 and bigger
				505	High	SR220 and bigger
Auger (std flow)	Boring of holes in the ground such as telegraph poles, electricity pylons, signposts, metallic frame pillars, tree and shrub planting	760	1.200	20 - 175	Std	All
Auger (high flow)		900	1.200	30 - 225	High	SR175 and bigger with High Flow
Farm Fork	General farm yard applications	1.525		153		SR130; SR150
		1.680		170		SR175 / SV185 / SR200
		1.850		185		SR175 / SV185 / SR200 / SR220 / SV250 / SR250 / SV300
		2.080		242		SR220 and bigger
Fork & Grapple	"Mucking out" bale and silage handling. Also suitable for industrial applications	1.525		250		SR130; SR150
		1.680		260		SR175 / SV185 / SR200
		1.850		310		SR175 / SV185 / SR200 / SR220 / SV250 / SR250 / SV300
		2.080		380		SR220 and bigger
Bale Spike	Handling of round bales	980		79		All
High Tip Bucket	Increase dump height by 800 to 1.200 mm	1.525		364		SR130 / SR150
		1.680		285		SR175 / SV185 / SR200
		1.850		352		SR175 / SV185 / SR200 / SR220 / SV250 / SR250 / SV300
		2.080		496		SR220 and bigger
4X1 Multipurpose Bucket	Applications as conventional bucket, grab for back filling or as a dozer	1.525		253		SR130 / SR150
		1.680		283		SR175 / SV185 / SR200
		1.850		340		SR175 / SV185 / SR200 / SR220 / SV250 / SR250 / SV300
		2.080		435		SR220 and bigger
Wide range of Buckets (Dirt&Foundry; Low Profile; Low Profile Extended, Heavy Duty, Manure/Slurry; Light Material)	Digging, excavating, grading, material handling	1.525				SR130 / SR150
		1.680				SR175 / SV185 / SR200
		1.830				SR175 / SV185 / SR200
		1.850				SR220 / SV250 / SR250 / SV300
		2.080				SR220 and bigger

SKID STEER LOADERS

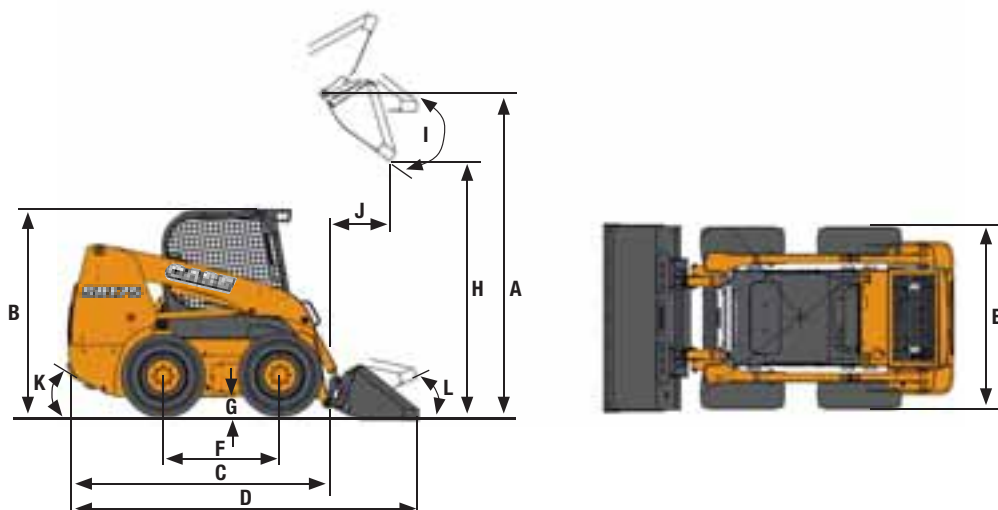

GENERAL DIMENSIONS

	SR130	SR150	SR175	SV185	SR200
A - Height to Bucket Hinge Pin	2.845 mm	2.845 mm	3.099 mm	3.048 mm	3.124 mm
B - Height to Top of ROPS	1.919 mm	1.919 mm	1.974 mm	1.974 mm	1.998 mm
C - Length without attachment	2.435 mm	2.435 mm	2.685 mm	2.710 mm	2.669 mm
D - Length with bucket *	3.028 mm	3.028 mm	3.305 mm	3.345 mm	3.292 mm
E - Overall Width	1.518 mm	1.518 mm	1.678 mm	1.678 mm	1.755 mm
F - Wheelbase	941 mm	941 mm	1.128 mm	1.128 mm	1.128 mm
G - Ground Clearance	178 mm	178 mm	178 mm	178 mm	203 mm
H - Dump height *	2.246 mm	2.246 mm	2.470 mm	2.377 mm	2.495 mm
I - Dump Angle	40°	40°	40°	52°	40°
J - Dump Reach @ Max Height	469 mm	469 mm	542 mm	783 mm	517 mm
K - Angle of Departure	22°	22°	23°	23°	25°
L - Rollback Angle (Bucket on Ground)	26°	26°	32°	35°	31°

* With D&F Bucket

SPECIFICATIONS

	SR130	SR150	SR175	SV185	SR200
PERFORMANCE SPECS					
Rated Operating Capacity 50%	590 kg	680 kg	790 kg	840 kg	905 kg
ROC with counterweights 50%	635 kg	725 kg	835 kg	885 kg	950 kg
Tipping Load	1.179 kg	1.361 kg	1.588 kg	1.678 kg	1.814 kg
Lift Cylinder Breakout Force*	19 kN	14 kN	17 kN	15,3 kN	20,3 kN
Bucket Cylinder Breakout Force*	18,5 kN	18,6 kN	32,3 kN	24,7 kN	32,3 kN
ENGINE					
Engine Brand	ISM	ISM	ISM	ISM	FPT
Displacement	2,2 l	2,2 l	2,2 l	2,2 l	3,2 l
Horsepower	49 hp @ 2.800 rpm	60 hp @ 2.800 rpm	60 hp @ 2.800 rpm	60 hp @ 2.800 rpm	74 hp @ 2.500rpm
Peak torque	143 Nm @1.800 rpm	171 Nm @ 1.800 rpm	171 Nm @ 1.800 rpm	171 Nm @ 1.800 rpm	275 Nm @ 1.400 rpm
TRAVEL SPEED					
Low Range	12,7 km/h	12,7 km/h	12,7 km/h	12,7 km/h	10,9 km/h
High Range (Optional)	NA	NA	18 km/h	18 km/h	15,9 km/h
HYDRAULIC SYSTEM					
Pump flow	59 LPM	59 LPM	72 LPM	72 LPM	85 LPM
Optional high flow	N/A	N/A	109 LPM	109 LPM	117 LPM
Relief Pressure	210 bar	210 bar	210 bar	210 bar	210 bar
WEIGHTS					
Operating Weight	2.300 kg	2.430 kg	2.842 kg	2.980 kg	3.160 kg
Shipping Weight	2.160 kg	2.300 kg	2.705 kg	2.840 kg	3.025 kg
SERVICE CAPACITY					
Fuel Tank	60,5 l	60,5 l	75,5 l	75,5 l	75,5 l

* Breakout forces estimated considering both tip and hydraulic limits

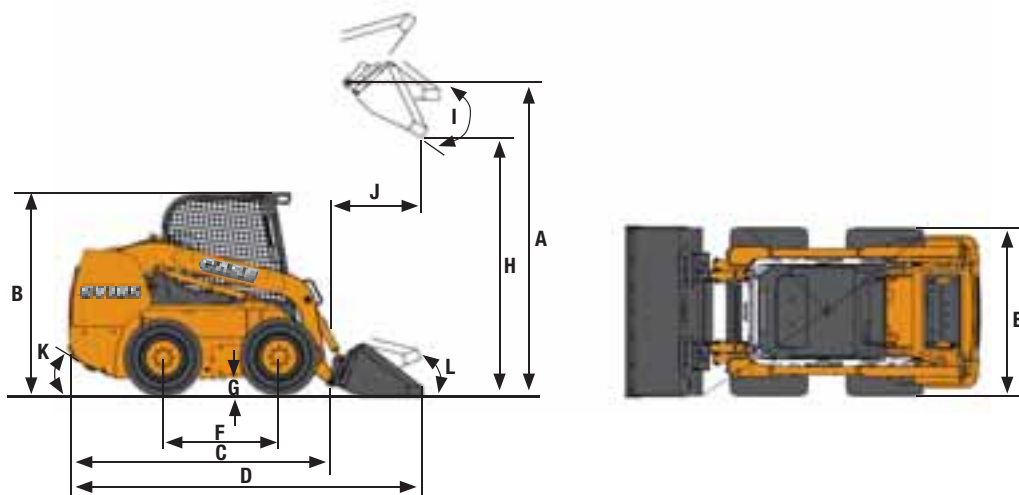

GENERAL DIMENSIONS

	SR220	SV250	SR250	SV300
A - Height to Bucket Hinge Pin	3.175 mm	3.302 mm	3.175 mm	3.302 mm
B - Height to Top of ROPS	2.002 mm	2.002 mm	2.002 mm	2.002 mm
C - Length without attachment	2.981 mm	2.990 mm	2.981 mm	2.990 mm
D - Length with bucket *	3.611 mm	3.604 mm	3.611 mm	3.604 mm
E - Overall Width	1.768 mm	1.768 mm	1.768 mm	1.768 mm
F - Wheelbase	1.322 mm	1.322 mm	1.322 mm	1.322 mm
G - Ground Clearance	203 mm	203 mm	203 mm	203 mm
H - Dump height *	2.558 mm	2.615 mm	2.558 mm	2.615 mm
I - Dump Angle	38°	54°	38°	54°
J - Dump Reach @ Max Height	495 mm	744 mm	575 mm	744 mm
K - Angle of Departure	24°	24°	24°	24°
L - Rollback Angle (Bucket on Ground)	31°	35°	31°	35°

* With D&F Bucket

SPECIFICATIONS

	SR220	SV250	SR250	SV300
PERFORMANCE SPECS				
Rated Operating Capacity 50%	1.000 kg	1.135 kg	1.135 kg	1.360 kg
ROC with counterweights 50%	1.090 kg	1.225 kg	1.225 kg	1.450 kg
Tipping Load	1.996 kg	2.268 kg	2.268 kg	2.722 kg
Lift Cylinder Breakout Force*	24,4 kN	21,4 kN	25,3 kN	24,9 kN
Bucket Cylinder Breakout Force*	38,7 kN	33,7 kN	33,3 kN	33,7 kN
ENGINE				
Engine Brand	FPT	FPT	FPT	FPT
Displacement	3,2 l	3,2 l	3,2 l	3,2 l
Horsepower	82 hp @ 2.500 rpm	82 hp @ 2.500 rpm	90 hp @ 2.500 rpm	90 hp @ 2.500 rpm
Peak torque	305 Nm @ 1.400 rpm	305 Nm @ 1.400 rpm	340 Nm @ 1.400 rpm	340 Nm @ 1.400 rpm
TRAVEL SPEED				
Low Range	11,3 km/h	11,3 km/h	11,3 km/h	12,4 km/h
High Range (Optional)	16,9 km/h	16,9 km/h	16,9 km/h	18,5 km/h
HYDRAULIC SYSTEM				
Pump flow	85 LPM	85 LPM	85 LPM	85 LPM
Optional high flow	131 LPM	131 LPM	131 LPM	131 LPM
Relief Pressure	210 bar	210 bar	210 bar	210 bar
WEIGHTS				
Operating Weight	3.350 kg	3.630 kg	3.490 kg	3.765 kg
Shipping Weight	3.200 kg	3.475 kg	3.340 kg	3.610 kg
SERVICE CAPACITY				
Fuel Tank	96,5 l	96,5 l	96,5 l	96,5 l

* Breakout forces estimated considering both tip and hydraulic limits



PARTS AND SERVICE

Wide network of customer support across the world.

No matter where you work, we're here to support and protect your investment and exceed your expectations. You can count on Case and your Case dealer for full-service solutions-productive equipment, expert advice, flexible financing, genuine Case parts and fast service. We're here to provide you with the ultimate ownership experience. To locate a Case dealer or learn more about Case equipment or customer service, go to www.casece.com

NOTE: CASE provides specific outfits for various countries and many optional fittings (OPT). The illustrations on this or other leaflets may relate to standard or optional fittings. Please consult your CASE dealer for any information in this regard and any possible updating on components. CNH Industrial reserves the right to modify machine specifications without incurring any obligation relating to such changes.

